



I gruppi M/330 riuniscono in una singola unità la funzione di filtro, regolatore e lubrificatore d'aria (M/330 = M/300 + M/350 + M/310).

- Predisposizione per il fissaggio al muro mediante staffa F/181/3
- Per le caratteristiche tecniche vedi i singoli componenti.

Les groupes M/330 réunissent en une seule unité la fonction de filtre-régulateur et lubrificateur (M/330 = M/300 + M/350 + M/310).

- Prédisposition pour la fixation mural à l'aide d'étrier F/181/3
- Pour les CARACTERISTIQUES TECHNIQUES, voir chaque composant.

The M/330 are all-in-one units combining a filter, regulator and lubricator (M/330 = M/300 + M/350 + M/310).

- Provision for wall-mounting with brackets F/181/3
- For the technical characteristics, see the single components.

Die Gruppe M/330 versammeln die funktionen Filter / Regler und Schmiervorrichtung (M/330 = M/300 + M/350 + M/310).

- Vorbereitet für Wandmontage mit Halterungen F/181/3
- Für die technischen Merkmale siehe die Einzelkomponenten.

M/330 SUPER

FILTRO - REGOLATORE - LUBRIFICATORE | MODULAR REGULATOR WITH FILTER AND LUBRICATOR
 FILTRE - RÉGULATEUR - LUBRIFICATEUR | FILTER - REGLE - SCHMIERVORRICHTUNG

COD.	MOD.	F	A	A1	B	B1	C	D	E		
AH115201	M/330/1	3/8F BSP	345	345	100	152	231	51	180	1	3539
AH115202	M/330/2	1/2F BSP	345	345	100	152	231	51	180	1	3539
AH115203	M/330/1-P	3/8F BSP	345	345	100	152	231	51	180	1	4235
AH115204	M/330/2-P	1/2F BSP	345	345	100	152	231	51	180	1	4235



M/330 SC SUPER

FILTRO - REGOLATORE - LUBRIFICATORE CON SCARICATORE AUTOMATICO CONDENSA
 MODULAR REGULATOR WITH FILTER AND LUBRICATOR WITH AUTOMATIC DRAIN
 FILTRE - RÉGULATEUR - LUBRIFICATEUR AVEC PURGE AUTOMATIQUE DE CONDENSATION
 FILTER - REGLE - SCHMIERVORRICHTUNG MIT AUTOMATISCHEM KONDENSATABLASS

COD.	MOD.	F	A	A1	B	B1	C	D	E		
AH115205	M/330/SC/1	3/8F BSP	345	370	100	152	241	51	190	1	3548
AH115206	M/330/SC/2	1/2F BSP	345	370	100	152	241	51	190	1	3548
AH115207	M/330/SC/1-P	3/8F BSP	345	370	100	152	241	51	190	1	4244
AH115208	M/330/SC/2-P	1/2F BSP	345	370	100	152	241	51	190	1	4264

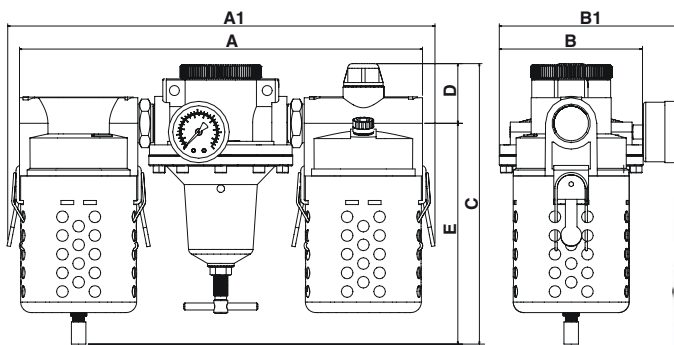

COMPOSIZIONE GRUPPO UNIT COMPOSITION COMPOSITION GROUPE ZUSAMMENSETZUNG DER GRUPPE										
M/330/1	=	M/300/1	+	F/180/2	+	M/350	+	F/180/2	+	M/310/1
M/330/2	=	M/300/2	+	F/180/3	+	M/350	+	F/180/3	+	M/310/2
M/330/1-P	=	M/300/1-P	+	F/180/2	+	M/350	+	F/180/2	+	M/310/1
M/330/2-P	=	M/300/2-P	+	F/180/3	+	M/350	+	F/180/3	+	M/310/2
M/330/SC/1	=	M/300/SC/1	+	F/180/2	+	M/350	+	F/180/2	+	M/310/1
M/330/SC/2	=	M/300/SC/2	+	F/180/3	+	M/350	+	F/180/3	+	M/310/2
M/330/SC/1-P	=	M/300/SC/1-P	+	F/180/2	+	M/350	+	F/180/2	+	M/310/1
M/330/SC/2-P	=	M/300/SC/2-P	+	F/180/3	+	M/350	+	F/180/3	+	M/310/2