

HL-410A

4POST 10TON FLAT PLATFORM LIFT

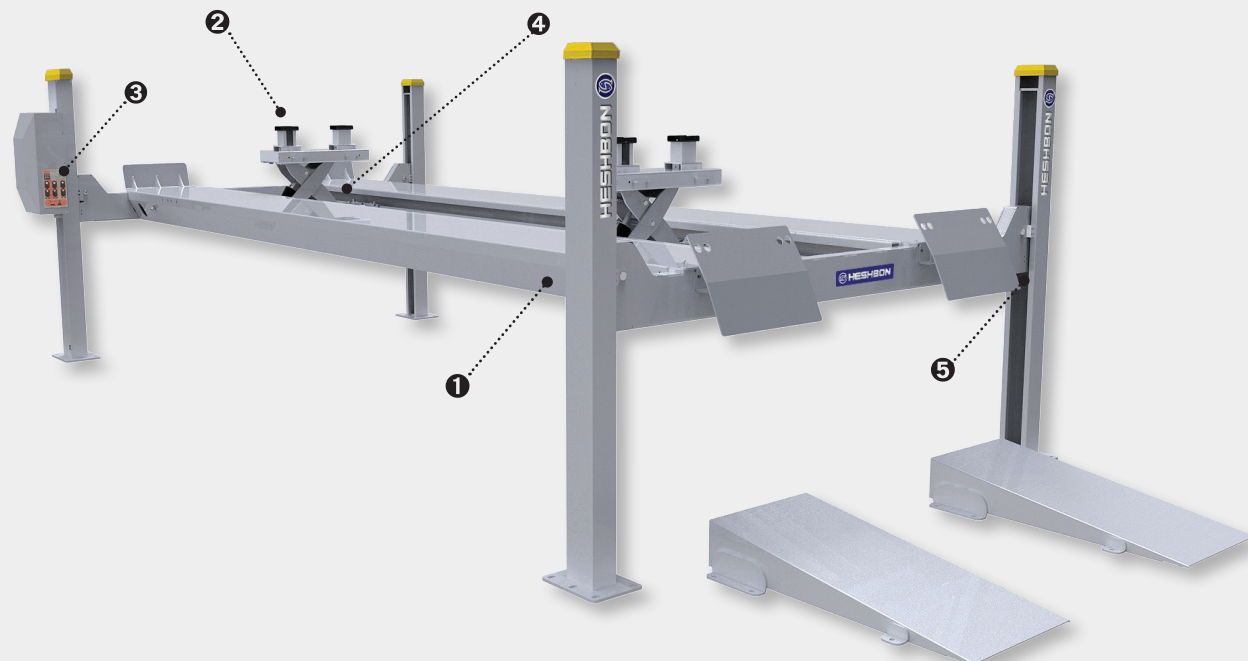
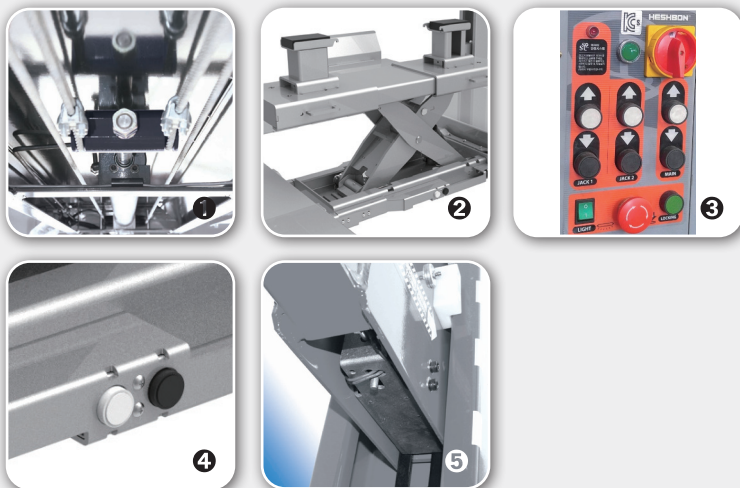

FEATURE

- Cylinder & Power pack ability for 10Ton Capacity.
- Auto control for center rolling jack.
- Hydraulic cylinder located in the fixed platform and it thus perfectly protected.
- High resistance galvanized and pre-stretched lifting cable.
- Lock released lever for the emergency situation.
- Adjustable parking ratchet rails ensure the platforms and cross members horizontal within 4 wheel alignment tolerances.
- Automatic spring loaded eccentric brake system in the event of cable breakage and ensure complete.
- Self-lubricated large diameter pulleys and maintenance-free bushes.
- Automatic alarm function to let user know wire exchange cycle.
- Hydraulic two-level 5ton scissor jack. (option)
- Electric remote-controller. (option)

SPECIFICATION

Model No.	HL-410A
Lifting Capacity (kg)	Body: 10,000kgs / Jack : 5,000kg
Max.Lifting Height (mm)	Body : 1,900mm / Jack : 795mm
Dimension (mm)	9,158(L) x 2,311(H)x 4,074(W)
Power Supply & Motor	3ph : 4PH,4P,220/380V,50/60Hz
Net Weight	3,800kg

LAY-OUT

