

# BLACKHAWK®



Air Driven Hydraulic Pumps  
**PMP81 Series**

The breakthrough in hydraulic pump  
technology & ergonomics.

700 bar pumps with  
XVARI® Technology



- ***Ergonomic design for less operator fatigue***
- ***Variable oil flow & fine metering for precise control***
- ***Higher oil flow for increased productivity***

## PMP81 Series, Air Driven Hydraulic Pumps

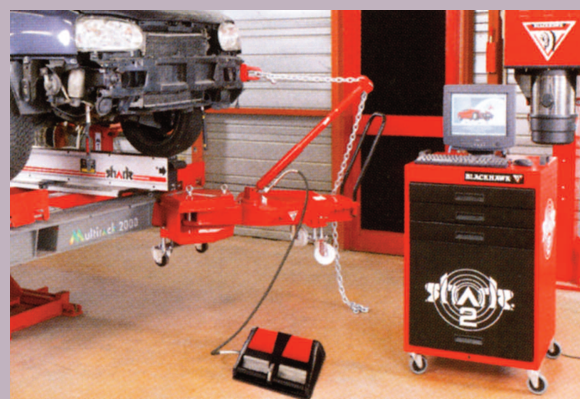

**XVARI® Technology**  
Product Application

The PMP81 pump can be used with all Blackhawk straightening systems and cylinders.

### Series PMP81



- Ergonomic design for less operator fatigue
- Variable oil flow & fine metering for precise control
- Higher oil flow for increased productivity
- Closed hydraulic system prevents contamination and allows pump usage in any position
- Pedal lock function for retract position
- Ground screw for improved ATEX explosion safety
- External adjustable pressure setting valve.

Reservoir Capacity :

**1,0 litre**

Flow at Rated Pressure :

**0,25 l/min**

Air Consumption :

**283 - 991 l/min**

Maximum Operating Pressure :

**700 bar**

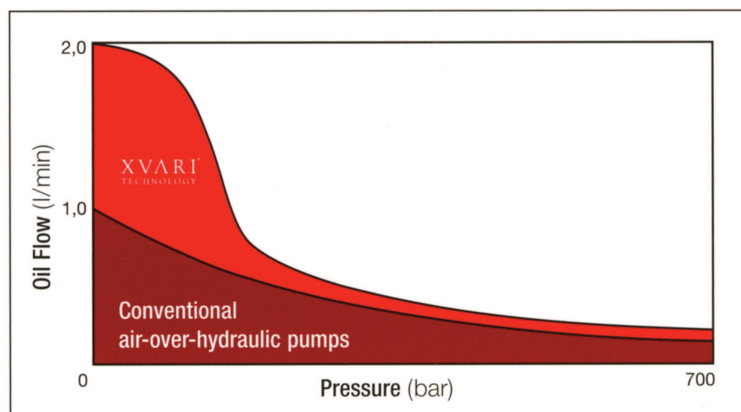

XVARI® Technology, Hydraulic Flow Performance

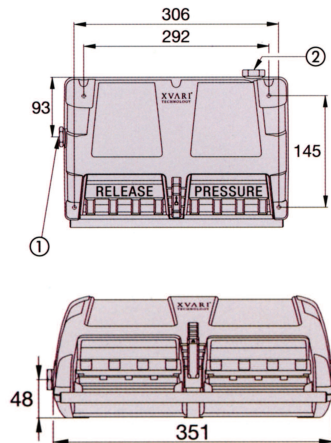



### FLOW CHART

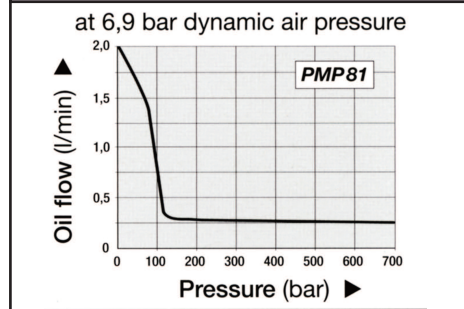

For use with cylinder or tool	Usable Oil Capacity (litres)	Maximum Pressure (bar)	Output Flow Rate (l/min)		Model Number	3-way 3-position Valve	Dynamic Air Pressure (bar)	(Kg)
			No load	Load				
Single-acting	1,0	700	2,0	0,25	<b>PMP81</b>	Advance/Hold/Retract	2,1-8,6	8,6

## BLACKHAWK SA

**France – Benelux** BP 5 – 67026 Strasbourg Cedex – FRANCE

Tel: 03 88 65 76 30 – Fax: 03 88 65 76 31 – E-Mail: info@blackhawk.fr

**International Sales** BP 5 – 67026 Strasbourg Cedex - FRANCE

Tel: +33 3 88 65 76 29 – Fax: +33 3 88 65 76 51 – E-Mail: export@blackhawk.fr

**Deutschland- Schweiz - Österreich** BP 5 – 67026 Strasbourg Cedex – FRANCE

Tel: +33 3 88 65 76 52 – Fax: +33 3 88 65 76 31 – E-Mail: info@blackhawk.de

**SNAP-ON EQUIPMENT SRL – BLACKHAWK ITALIA**

Via Provinciale Carpi 33 – I-42015 Correggio – RE - ITALY

Tel: 0522 733620 – Fax: 0522 733621 – E-Mail: blackhawk@snapon.com

**SNAP-ON EQUIPMENT - BLACKHAWK UK**

48 Suttons Park Avenue - Reading RG6 1AZ UK

Tel: 01303 270273 - Fax: 01303 270274 - Email: sales@blackhawk.co.uk

www.blackhawk.fr  
www.blackhawk.de  
www.blackhawk.it  
www.blackhawk.co.uk

